

1

2

3

4

Technical sheet / Datos técnicos:

Part number adaptable to / Referencia adaptable a	4324130700
Opening pressure of safety valve / Presión de apertura válvula de seguridad	14,5 bar
Unloader / Regulador de presión	Integrated / Integrado
Cut-out pressure / Presión de corte	8,5 ± 0,2 bar
Heating / Calentador	100 W/ 24 V
Cut-in temperature / Temperatura de cierre	+7 ± 6 °C
Cut-off temperature / Ajuste de la temperatura	+29,5 ± 3 °C
Permissible medium / Medio de funcionamiento	Air / Aire
Operating temperature range / Rango de temperatura	-40 °C to / a +65 °C
Weight / Peso	4750 gr

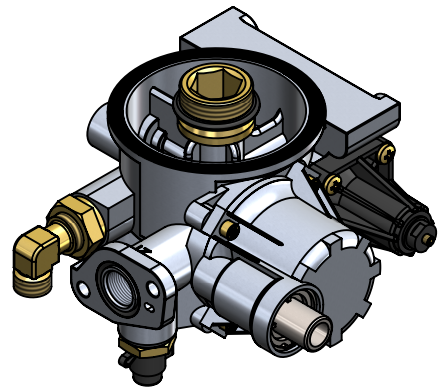
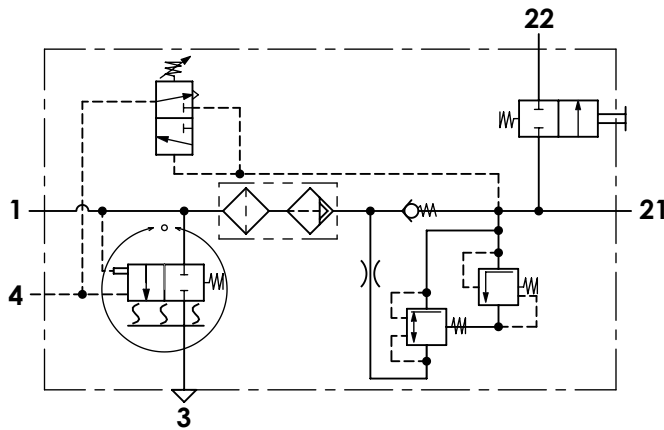

Port / Conexión	Function / Función	Thread / Rosca
1	Supply from air compressor / Alimentación desde el compresor de aire	M22x1,5 + Adaptor/Adaptador 90° M22x1,5
21	Delivery to air reservoirs / Salida a calderines de aire	M22x1,5
22	Delivery to tire inflation device / Salida para dispositivo de inflado de neumáticos	M16x1,5
4	Control to air compressor / Pilotaje al compresor de aire	M12x1,5
3	Exhaust / Escape	-
6	Heating / Calentador	Bayonet DIN 72585 A1-2

Purpose / Propósito:

Drying of the compressed air supplied by the compressor. / Secado del aire comprimido procedente del compresor.

Installation requirements / Requisitos para la instalación:

Exhaust (3) must look down. / El escape (3) debe estar orientado hacia abajo.

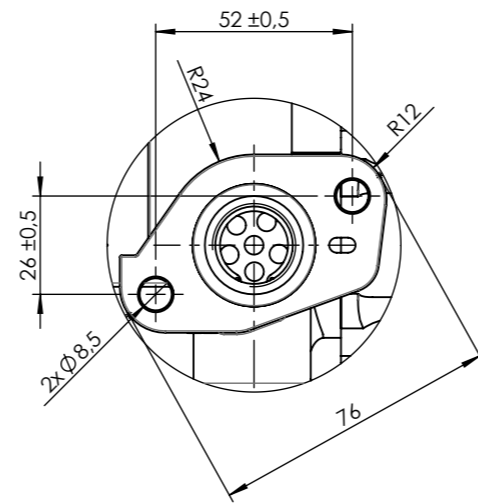
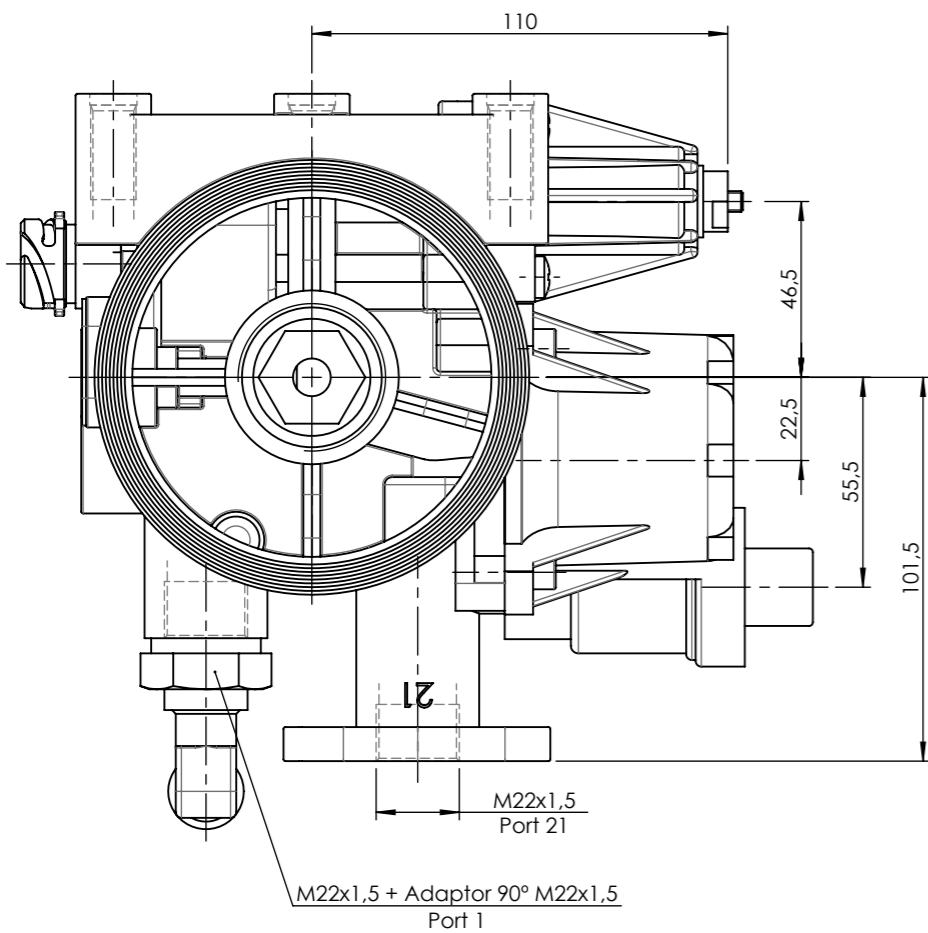
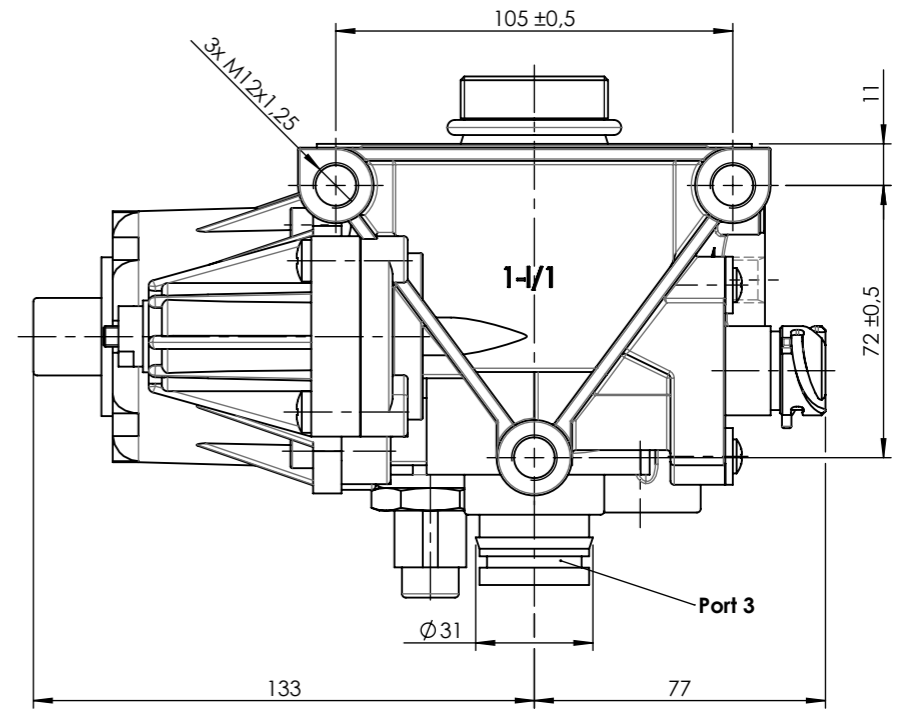
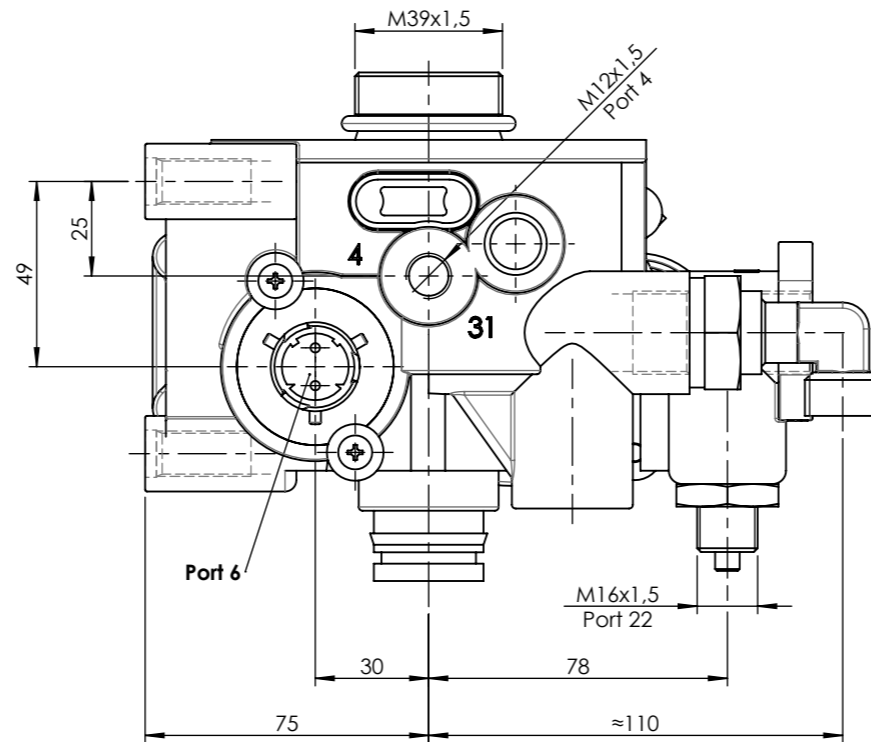
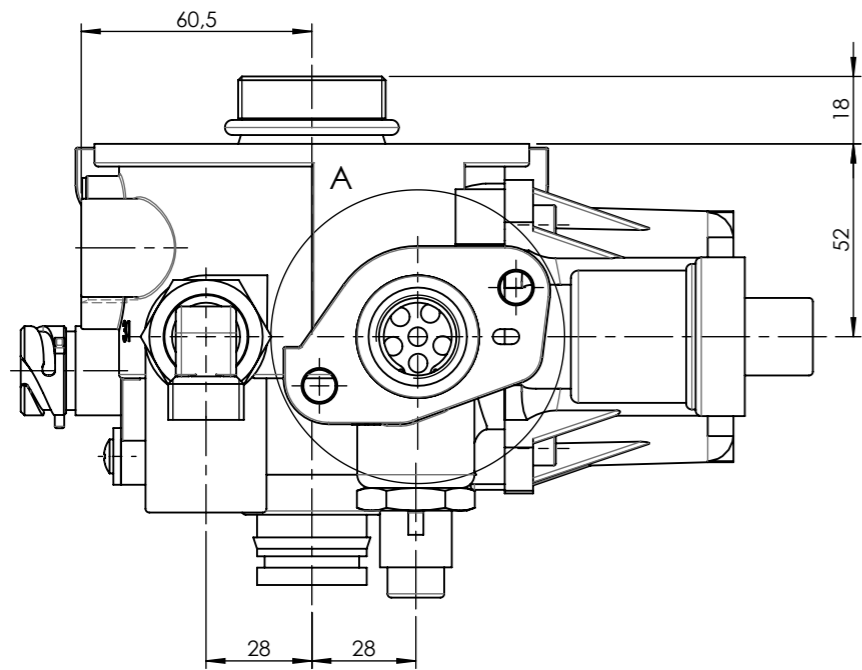

Modification	4				Drawn		
	3				22/01/18 J.S.		
	2				Checked		
	1				22/01/18 O.V.		
	nº	Modified	Date	Reason	General Tolerance		Assembly
Comments					-	Part name	Air dryer
					Material	ID. Reference	2210267
					-	Scale: -	
					-	Review: 0	

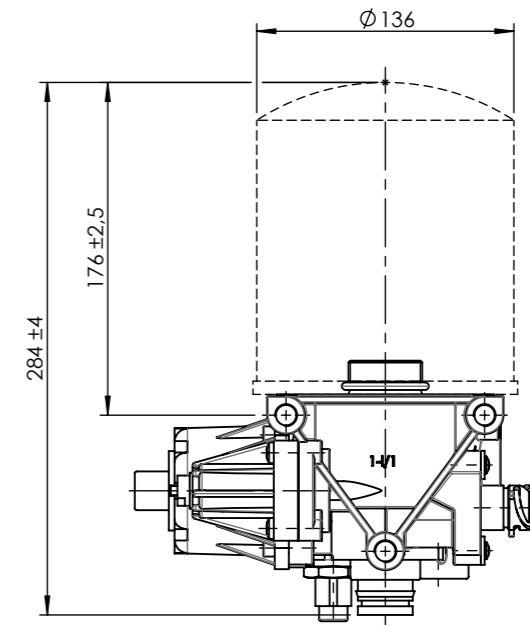

DETAIL / DETALLE A



SCALE / ESCALA 1 : 4

Modification	4			Drawn			
	3			22/01/18 J.S.			
	2			Checked			
	1			22/01/18 O.V.			
	nº	Modified	Date	Reason	General Tolerance	Assembly	-
Comments					ISO 2768 c-K	Part name	Air dryer
					Material	ID. Reference	2210267
						Scale: 1/2	
						Review: 0	