

1

2

3

4

**Technical Sheet / Datos técnicos:**

Type / Tipo:	T-20
Max. working pressure / Presión máxima de trabajo:	10 bar
Permissible Medium / Medio de funcionamiento:	Aire / Air
Operating temperature range / Rango de temperatura:	- 40°C a / to +70°C
Operating stroke / Carrera funcional:	75 mm
Weight / Peso:	3.800 gr

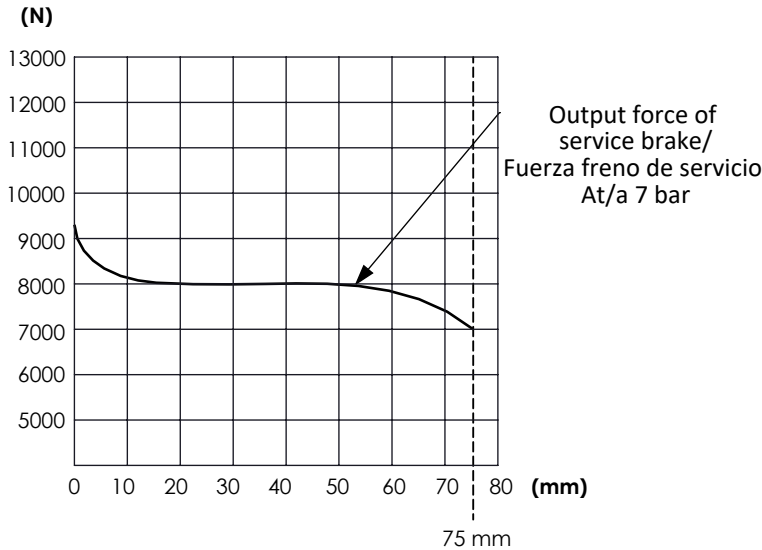
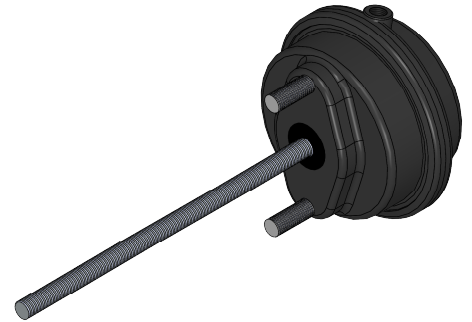
**Force diagram / Diagrama de fuerzas****Pneumatic scheme / Esquema neumático****Purpose / Propósito:**

To generate the braking force for the wheel brakes. It can also be used for other purposes, e.g. clamping, lifting and actuating /

Generar la fuerza de frenado necesaria para los frenos de las ruedas. También puede utilizarse para otros propósitos por ejemplo para fijación, elevación y actuamiento

**Installation Requirements / Requisitos para la instalación:**

The diaphragm should be installed with bleed hole pointing downwards and with the link joint slanting downwards so that any water that is splashed into the unit can drain out. When installing the brake chamber, care should be taken that the brake line is not positioned lower than the actuator unit / El diafragma debe instalarse con el orificio de purga orientado hacia abajo y con la articulación de unión inclinada hacia abajo, de tal forma que el agua que pueda entrar en la unidad como consecuencia de salpicaduras pueda salir. Al montar la cámara de freno debe tenerse la precaución de procurar que la tubería del freno no quede situada por debajo de la unidad del actuador

Modification	4				Drawn		
	3				12/08/15 A.U.		
	2				Checked		
	1				12/08/15 A.L.		
	nº	Modified	Date	Reason	General Tolerance		Assembly
Comments					-	Part name	BRAKE CHAMBER / CÁMARA FRENO DE TAMBOR T-20
					Material	ID. Reference	2251104
					-	Scale: -	
					-	Review: 0	

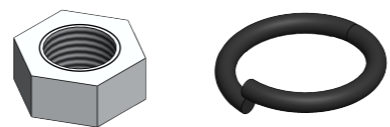
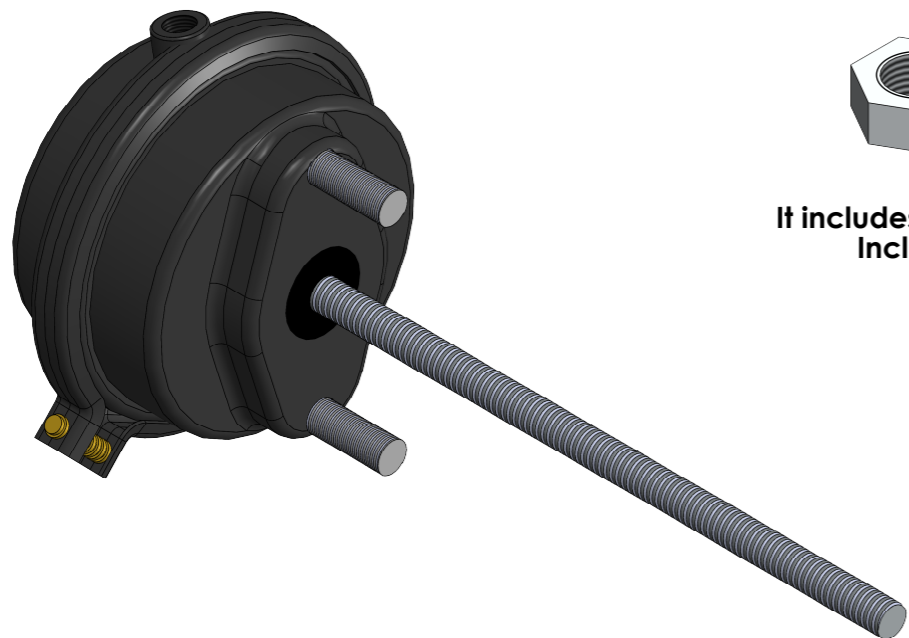
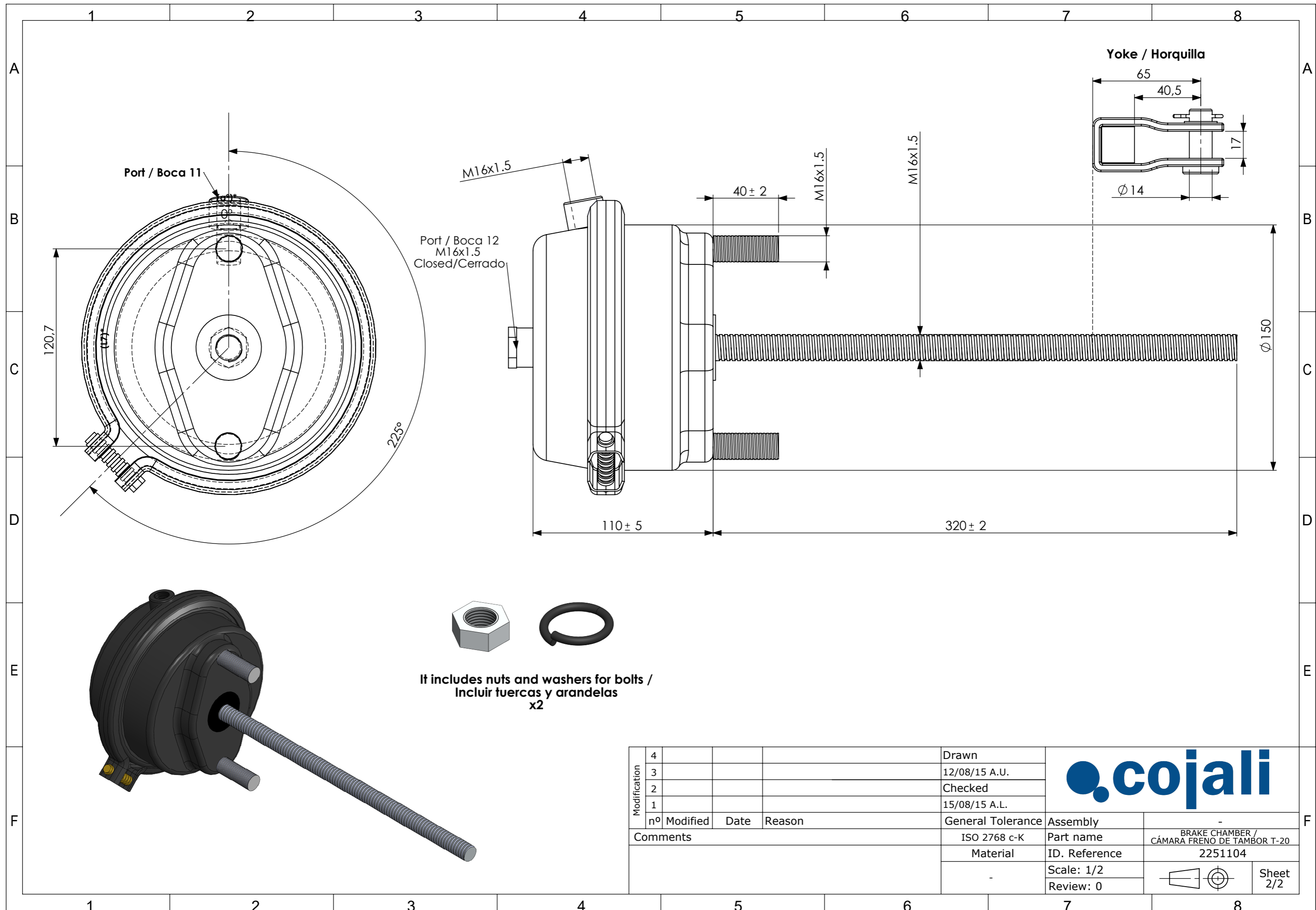

It includes nuts and washers for bolts /  
Incluir tuercas y arandelas  
x2

Modification	4			Drawn	
	3			12/08/15 A.U.	
	2			Checked	
	1			15/08/15 A.L.	
	nº Modified	Date	Reason	General Tolerance	Assembly
Comments				ISO 2768 c-K	Part name
				Material	ID. Reference
				-	Scale: 1/2
					Review: 0
					Sheet 2/2

BRAKE CHAMBER / CÁMARA FRENO DE TAMBOR T-20

2251104