

1

2

3

4

A

Technical sheet / Datos técnicos:

A

Part number adaptable to / Referencia adaptable a	9522010040
Supply pressure / Presión de alimetación	max 8,5 bar
Test coupling / Conexión de test	No
Vehicle / Vehículo	Trailer / Remolque
Usage / Aplicación	Supply / Alimentación
Integrated filter / Filtro integrado	Yes / Sí
Permissible medium / Medio de funcionamiento	Air / Aire
Operating temperature range / Rango de temperatura	-40 °C to / a +80 °C
Weight / Peso	260 gr

B

B

C

C

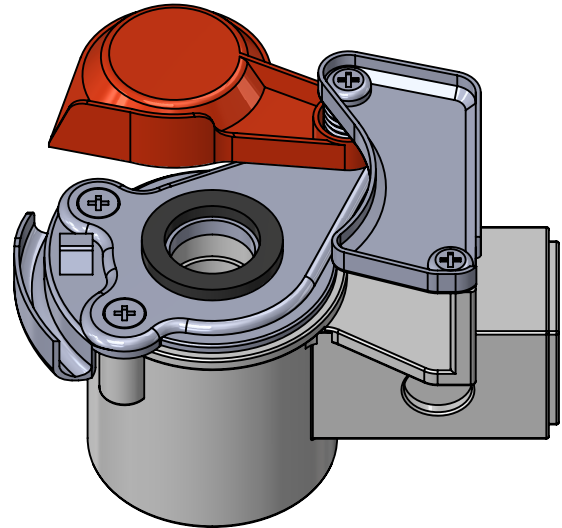
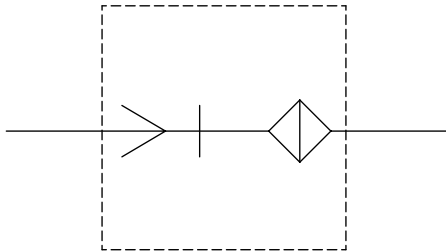

D

D

Port / Conexión	Thread / Rosca
1	M16x1.5

E

E

Purpose / Propósito: To connect the pneumatic brake system of the truck or semi-trailer tractor with the trailer's brake system. / Conectar el sistema de frenado neumático del camión o del tractor de semirremolque con el sistema de frenado del remolque.

Installation requirements / Requisitos para la instalación: To fit in accordance with the ISO 1728 standard. / Instalar según la norma ISO 1728.

F

F

Modification	4				Drawn			
	3				18/12/14 A.U.			
	2				Checked			
	1				18/12/14 A.L.			
	nº	Modified	Date	Reason	General Tolerance		Assembly	-
Comments					-	Part name	Coupling head	
					Material	ID. Reference	6001423	
					-	Scale: -		Sheet 1/2
					-	Review: 0		

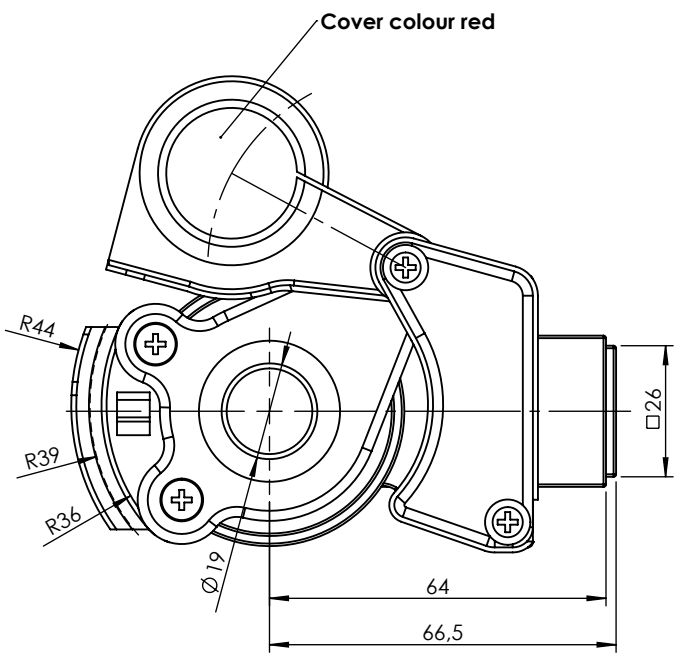
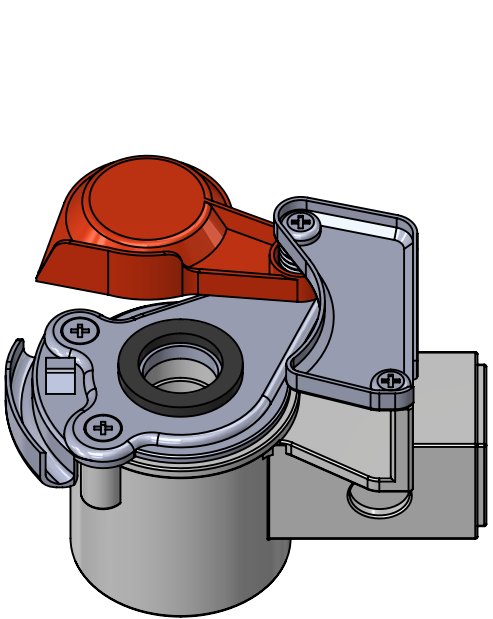
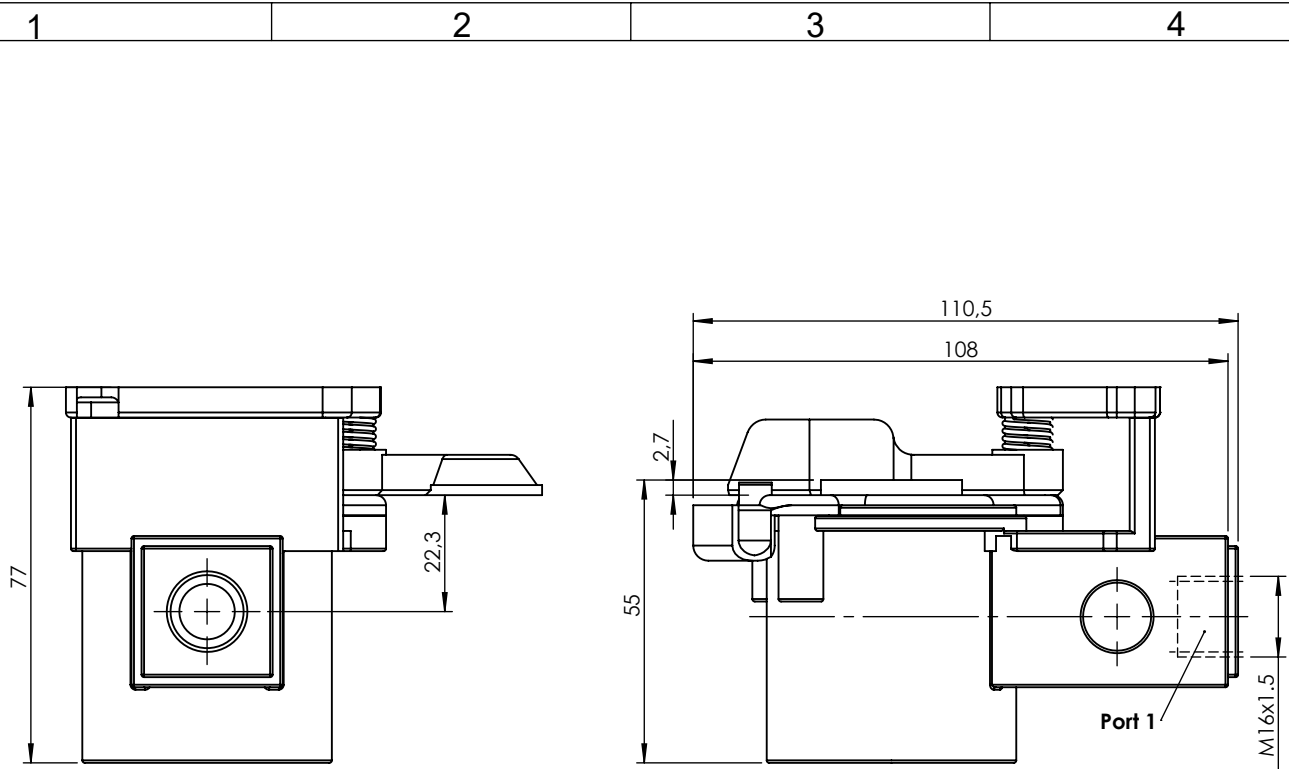

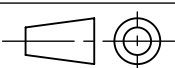
F	Modification	4				Drawn		F
		3				18/12/14 A.U.		
		2				Checked		
		1				18/12/14 A.L.		
	nº	Modified	Date	Reason	General Tolerance	Assembly		
Comments					ISO 2768 c-K	Part name	Coupling head	
					Material	ID. Reference	6001423	
					-	Scale: 2/3		Sheet 2/2
					-	Review: 0		
PG/18/02 rev.1 1					2	3	4	