

SECTION A-A

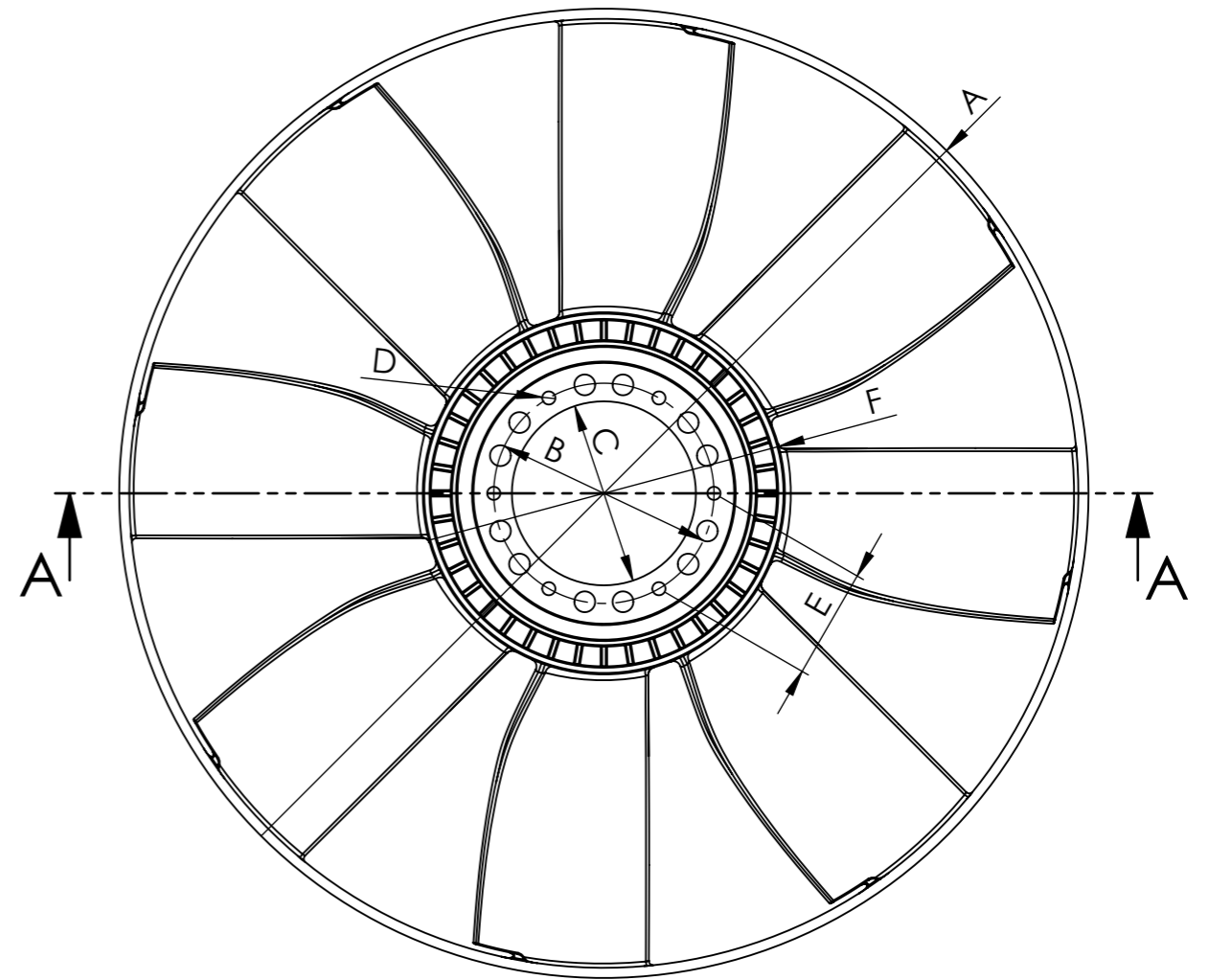
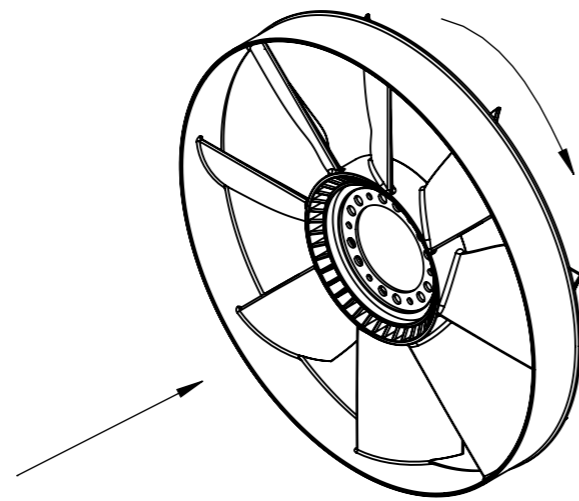

Dimensional values	FAN WHEEL			
	Ref.n°	Value	Ref.n°	Value
	A	$\varnothing 656 \pm 3$ mm	G	59 ± 3 mm
	B	$\varnothing 152.4$ mm	H	52.5 ± 3 mm
	C	$\varnothing 127 +0.30$ mm	I	112.6 ± 3 mm
	D	6x $\varnothing 9$ mm	J	$\varnothing 648 \pm 3$ mm
	E	76.2 mm		
	F	$\varnothing 250 \pm 3$ mm		
	Number of blades		8	Configuration
				CW

Modification n°	Modified	Date	Reason	Comments	Drawn
					4
3					Checked
2					24/11/20 A.R.
1					

General Tolerance		ISO 2768 c-K	Assembly	Technical sheet
Material			Part name	Fan wheel
ID. Reference		8822608	ID. Reference	8822608
Scale: 1/5			Review: 0	
Review: 0				
				Sheet 1/1

