

1

2

3

4

## A Technical sheet / Datos técnicos:

|  |                    |
|--|--------------------|
| Part number adaptable to / Referencia adaptable a  | 4613150000         |
| Operating pressure / Presión de trabajo            | max. 10 bar        |
| Predominance / Predominancia                       | ≤ 0,3 bar          |
| Permissible medium / Medio de funcionamiento       | Air / Aire         |
| Operating temperature range / Rango de temperatura | -40°C to / a +80°C |
| Weight / Peso                                      | 1100 gr            |

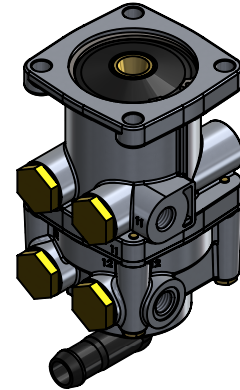
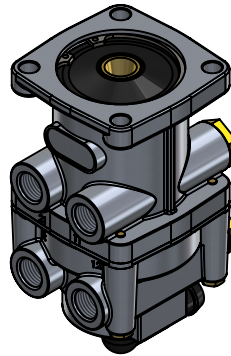
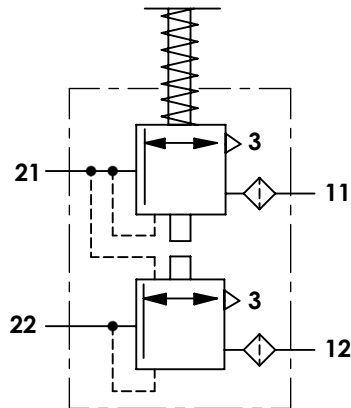

| Port / Conexión | Function / Función    | Thread / Rosca    |
|-----------------|-----------------------|-------------------|
| 11              | Supply / Alimentación | M16x1,5 & M12x1,5 |
| 12              | Supply / Alimentación | M16x1,5 & M12x1,5 |
| 21              | Delivery / Salida     | M16x1,5           |
| 22              | Delivery / Salida     | M16x1,5           |
| 3               | Exhaust / Escape      | Tube / Tubo 90°   |

### Purpose / Propósito:

Application of service brake system through the pedal actuation by the driver. / Aplicación del freno de servicio mediante la actuación del pedal por parte del conductor.

### Installation requirements / Requisitos para la instalación:

The design of the foot brake valve, acting on seat, must guarantee the maximum way of the push rod that is necessary to control the valve even in case of failure in the circuit I. Mounting is accomplished using four screws M8. / El diseño de la válvula de freno de pie, accionándolo desde el asiento, debe garantizar el máximo recorrido de la varilla de empuje que resulta necesario para el accionamiento de la válvula, incluso en caso de que falle el circuito I. El montaje se efectúa mediante cuatro tornillos M8.

|          |              |    |          |      |          |                   |                  |
|----------|--------------|----|----------|------|----------|-------------------|------------------|
| F        | Modification | 4  |          |      |          | Drawn             |                  |
|          |              | 3  |          |      |          | 24/11/15 A.U.     |                  |
|          |              | 2  |          |      |          | Checked           |                  |
|          |              | 1  |          |      |          | 24/11/15 A.L.     |                  |
|          |              | nº | Modified | Date | Reason   | General Tolerance |                  |
| Comments |              |    |          |      | -        | Part name         | Foot brake valve |
|          |              |    |          |      | Material | ID. Reference     | 2212200          |
|          |              |    |          |      | -        | Scale: -          |                  |
|          |              |    |          |      | -        | Review: 0         |                  |

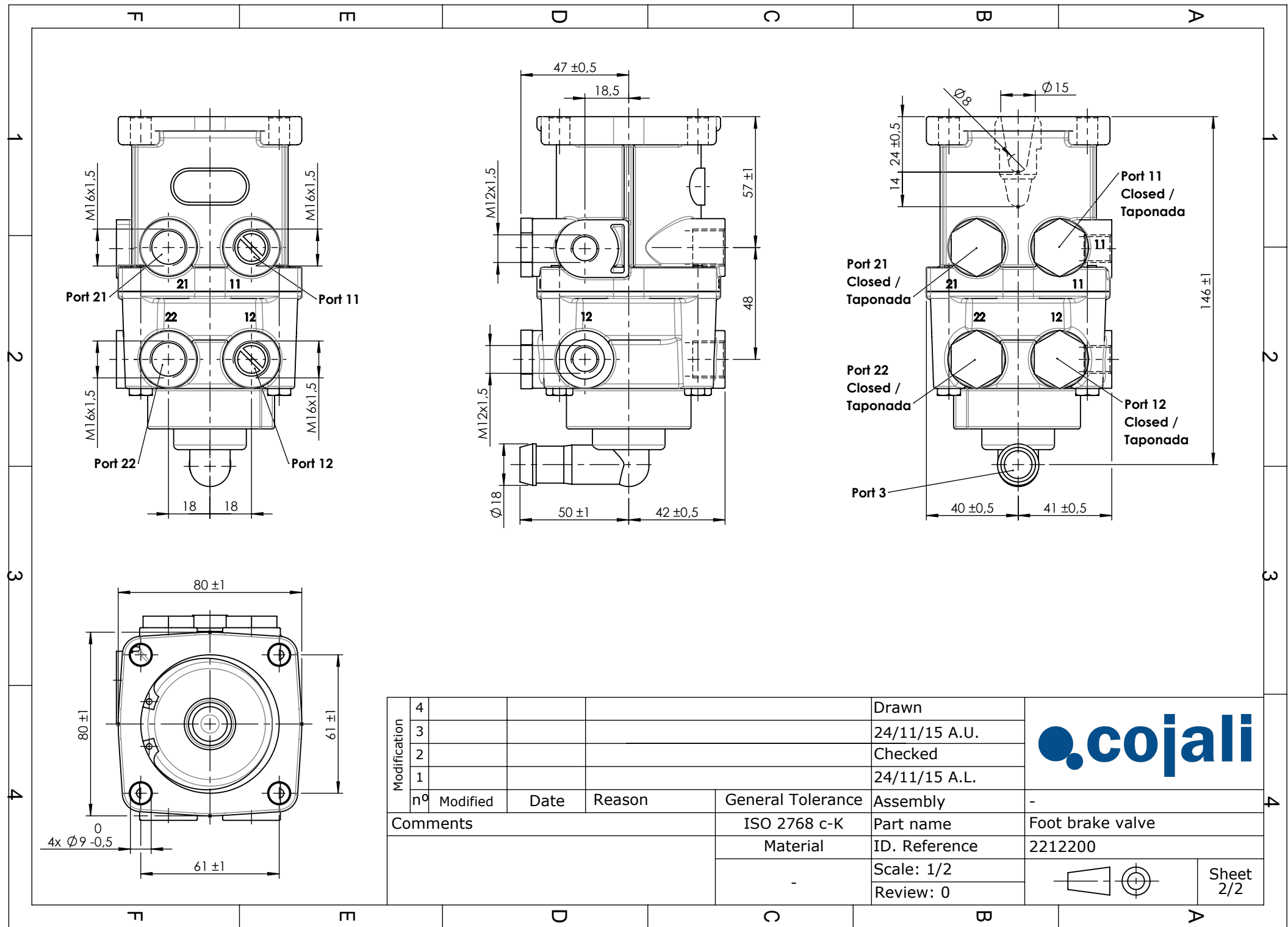

|              |          |      |        |                   |               |                  |
|--------------|----------|------|--------|-------------------|---------------|------------------|
| Modification | 4        |      |        |                   | Drawn         |                  |
|              | 3        |      |        |                   | 24/11/15 A.U. |                  |
|              | 2        |      |        |                   | Checked       |                  |
|              | 1        |      |        |                   | 24/11/15 A.L. |                  |
| nº           | Modified | Date | Reason | General Tolerance | Assembly      |                  |
| Comments     |          |      |        | ISO 2768 c-K      | Part name     | Foot brake valve |
|              |          |      |        | Material          | ID. Reference | 2212200          |
|              |          |      |        |                   | Scale: 1/2    |                  |
|              |          |      |        |                   | Review: 0     |                  |

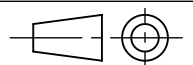

Sheet  
2/2