

1

2

3

4

A Technical sheet / Datos técnicos:

Part number adaptable to / Referencia adaptable a	9617231090
Operating pressure / Presión de trabajo	max. 10 bar
Actuation angle / Ángulo de accionamiento	73°
Permissible medium / Medio de funcionamiento	Air / Aire
Operating temperature range / Rango de temperatura	-40°C to / a +80°C
Weight / Peso	600 gr

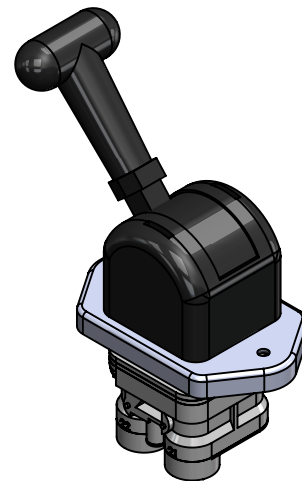
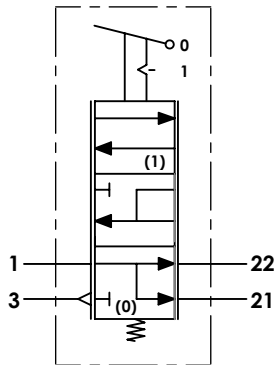

Port / Conexión	Function / Función	Thread / Rosca
1	Supply / Alimentación	M16x1.5
21	Delivery to relay valve / Salida a válvula relé	M16x1.5
22	Delivery to trailer control valve / Salida a válvula control remolque	M16x1.5
3	Exhaust / Escape	-

Purpose / Propósito: Parking braking actuation due to pressure release of spring brakes actuators. / Accionamiento del freno de estacionamiento gracias al alivio de la presión en las cámaras de muelle de los actuadores de freno.

Installation requirements / Requisitos para la instalación: The valve is fastened using two screws M6. / La válvula es fijada usando dos tornillos M6.

F	Modification	4				Drawn	
		3				09/09/15 A.U.	
		2				Checked	
		1				09/09/15 A.L.	
		nº	Modified	Date	Reason	General Tolerance	
Comments					-	Part name	Hand brake valve
					Material	ID. Reference	2224529
					-	Scale: -	
					-	Review: 0	

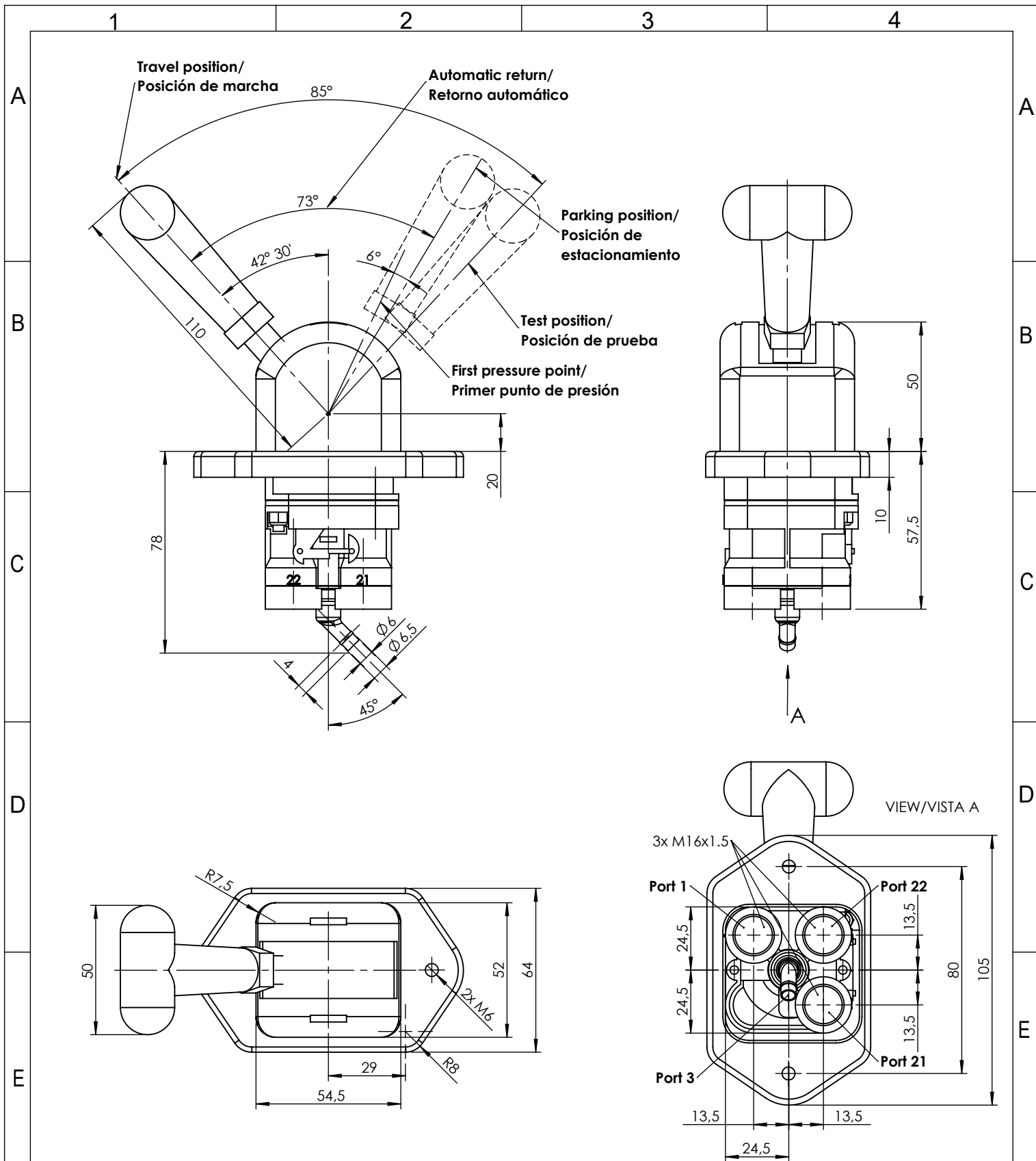

F	Modification	4				Drawn		F
		3				09/09/15 A.U.		
		2				Checked		
		1				09/09/15 A.L.		
	nº	Modified	Date	Reason	General Tolerance	Assembly		
Comments					ISO 2768 c-K	Part name	Hand brake valve	
					Material	ID. Reference	2224529	
					-	Scale: 1/2		Sheet 2/2
					-	Review: 0		