

1

2

3

4

A

Technical sheet / Datos técnicos:

Part number adaptable to / Referencia adaptable a	K0384381N50
Working pressure / Presión de trabajo	max. 10.2 bar
Type of current / Tipo de corriente:	Direct current / Corriente continua
Voltage / Voltaje:	24 V
Nominal current / Corriente nominal:	1.65 A
Permissible medium / Medio de funcionamiento	Air / Aire
Operating temperature range / Rango de temperatura	-40 °C to / a +80 °C
Weight / Peso	600 gr

A

B

B

C

C

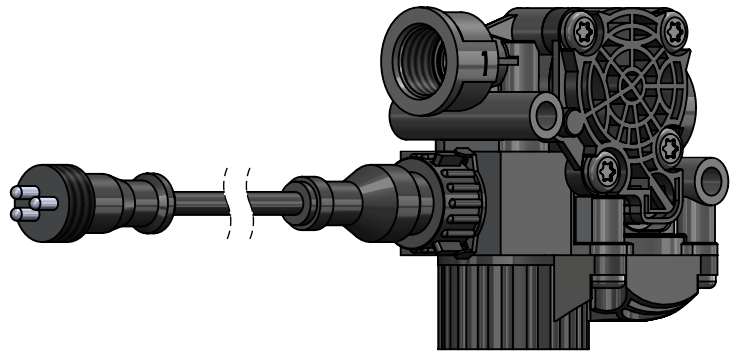
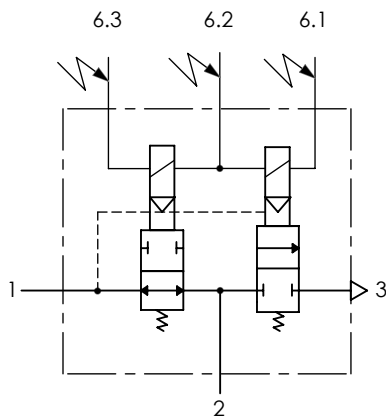

D

D

Port / Conexión	Function / Función	Thread / Rosca
1	Supply / Alimentación	M22x1.5 VOSS
2	Delivery / Salida	M22x1.5 VOSS
3	Exhaust / Escape	-
6	Conector / Conector	M24x1

Purpose / Propósito: Increase, reduce or maintain the pressure in the brake cylinders during a braking process according to the regulation of the ABS electronic control unit. / Aumentar, reducir o mantener la presión en los cilindros de freno durante un proceso de frenado según la regulación de la unidad de control electrónico ABS.

E

E

Installation requirements / Requisitos para la instalación: To install the modulator with the exhaust port facing downwards. The modulator must be installed using two screws M8. / Instalar el modulador con el escape orientado hacia abajo. El modulador debe ser instalado utilizando dos tornillos M8.

F

F

Modification	4				Drawn			
	3				26/10/20 S.F.			
	2				Checked			
	1				26/10/20 O.V.			
	nº	Modified	Date	Reason	General Tolerance		Assembly	-
Comments					-	Part name	ABS Modulator	
					Material	ID. Reference	2309215	
					-	Scale: -		Sheet 1/2
					-	Review: 0		

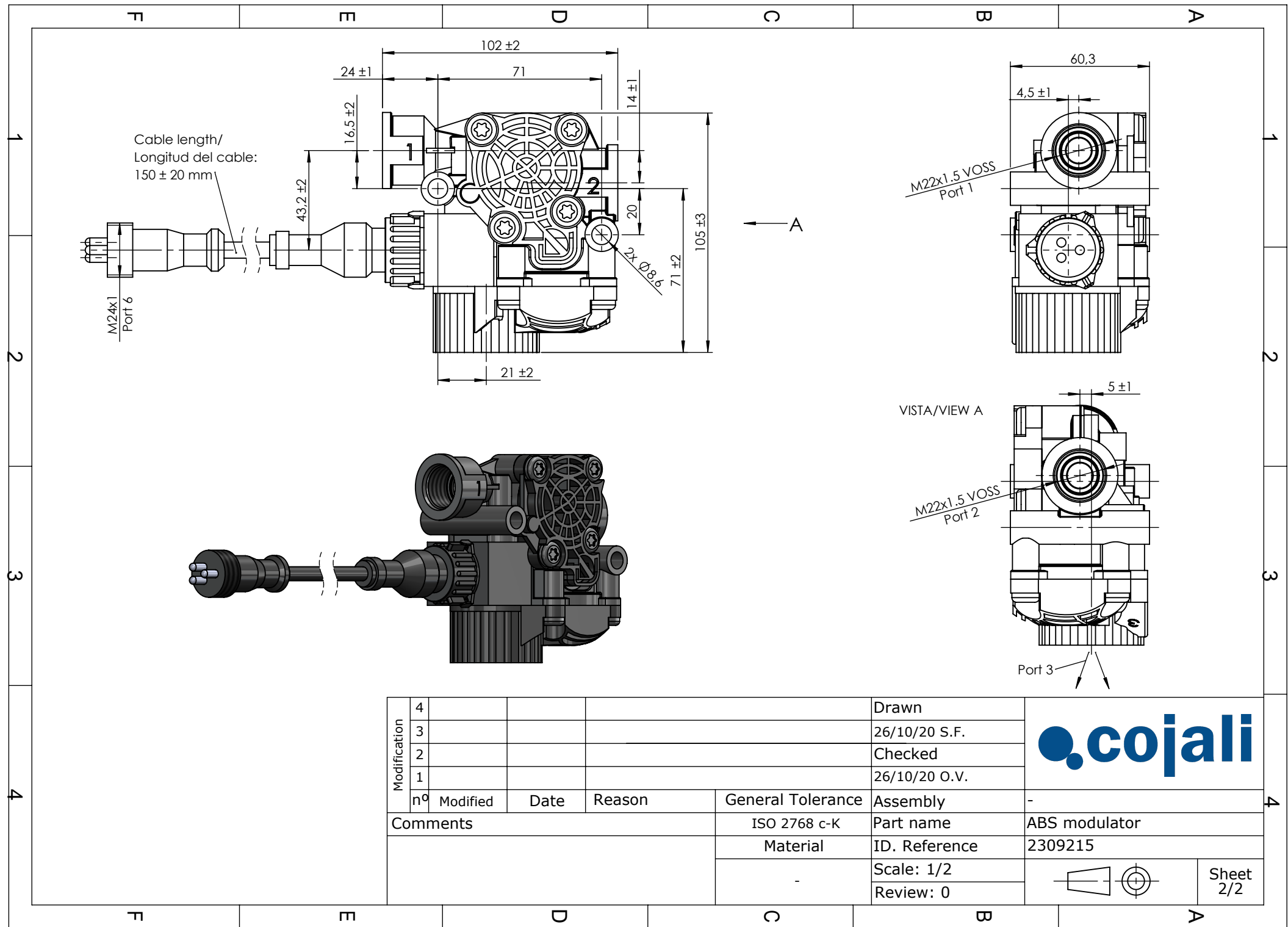

Modification	4				Drawn
	3				26/10/20 S.F.
	2				Checked
	1				26/10/20 O.V.
	nº	Modified	Date	Reason	General Tolerance
Comments					ISO 2768 c-K
					Assembly
					Part name
					ID. Reference
					Scale: 1/2
					Review: 0

cojali

ABS modulator

2309215

Sheet 2/2