

Dimensional values	INPUT SHAFT		FAN CLUTCH WHEEL	
	Ref.n°	Value	Ref.n°	Value
	A	$\varnothing 24 \pm 0.20 \text{ mm}$	F	$\varnothing 410 \pm 3 \text{ mm}$
	B	$\varnothing 56 \text{ mm}$	G	$\varnothing 194 \pm 3 \text{ mm}$
	C	$\varnothing 70 \text{ mm}$	H	$77.5 \pm 1 \text{ mm}$
	D	4x $\varnothing 7 \text{ mm}$	I	$78.3 \pm 3 \text{ mm}$
	E	$13.5 \pm 2 \text{ mm}$	J	$31.1 \pm 3 \text{ mm}$
		Number of blades		8
		Configuration		CW

Modification	n°	Modified	Date	Reason
	4			
3				
2				
1				

Comments

Drawn
02/07/20 J.S.

Checked
02/07/20 V.P.

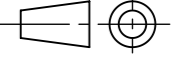

General Tolerance	ISO 2768 c-K
Assembly Part name	Technical sheet Fan clutch wheel
ID. Reference	8120107
Scale:	1/3
Review:	0

 **Sheet 1/1**